

Summer Assignment For Incoming 2nd Graders

Welcome to 2nd Grade:

Research shows that over the summer break, children can lose over two months' of math learning. To help beat this Summer Slide, scholars have been given a Math Summer Assignment. The completed assignment is due on August 15th and will be worth a Grade.

We wish you a great Summer Break!





Sincerely,





Archimedean Academy
Math Team





Making 10











Color some fish green, and write the correct numbers in the boxes.







 green white
 + = 10



 green white
 + = 10



 green white
 + = 10



 green white
 + = 10



 green white
 + = 10



 green white
 + = 10

Write the missing numbers in the boxes to make 10.

10 + <input type="text" value="0"/> = 10	6 + <input type="text"/> = 10	2 + <input type="text"/> = 10
9 + <input type="text"/> = 10	5 + <input type="text"/> = 10	1 + <input type="text"/> = 10
8 + <input type="text"/> = 10	4 + <input type="text"/> = 10	0 + <input type="text"/> = 10
7 + <input type="text"/> = 10	3 + <input type="text"/> = 10	

Odd or even?



Add or subtract to find the answers.
Choose two colors. Color the odd houses one color
and the even houses another color.

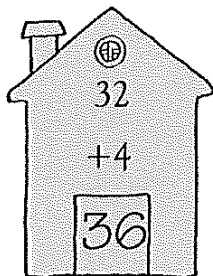

even

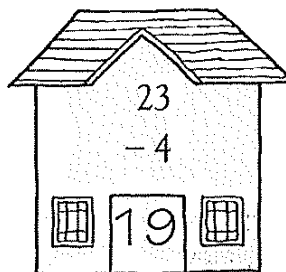

odd

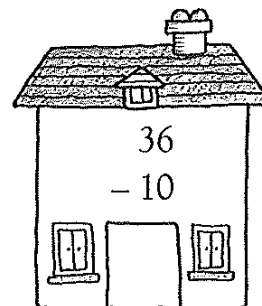
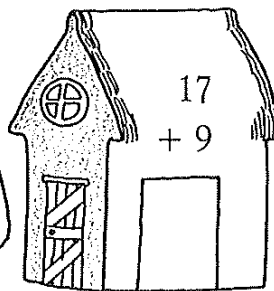
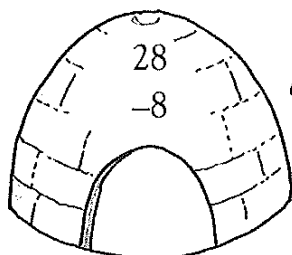
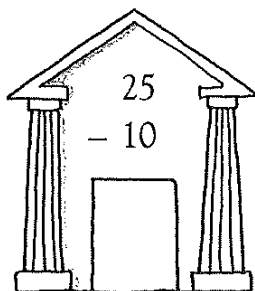
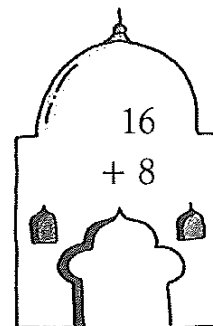
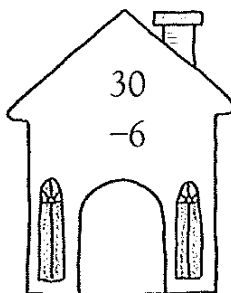
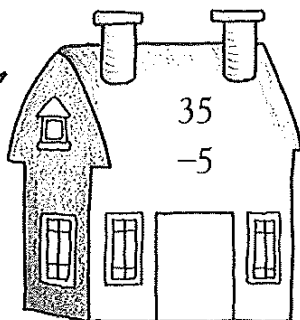
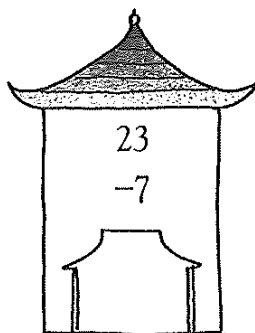
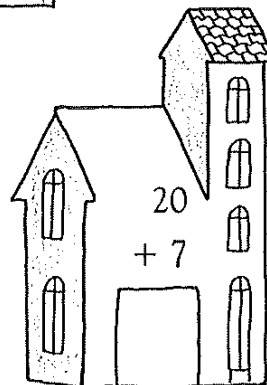
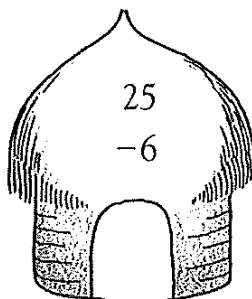
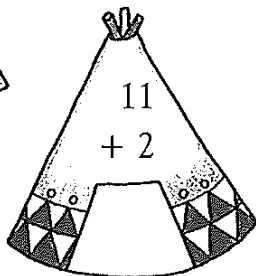
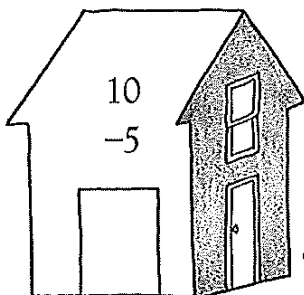

Odds and evens



Write the answer in the box.

$3 + 3 = 6$

$4 + 6 = 10$

$7 + 3 = 10$

$2 + 6 = 8$

Add the even numbers to the even numbers.

$4 + 8 =$

$12 + 6 =$

$10 + 6 =$

$8 + 14 =$

$20 + 14 =$

$14 + 12 =$

$16 + 10 =$

$30 + 20 =$

$14 + 16 =$

$18 + 6 =$

$22 + 8 =$

$20 + 40 =$

What do you notice about each answer? _____

Add the odd numbers to the odd numbers.

$7 + 9 =$

$5 + 7 =$

$11 + 5 =$

$9 + 5 =$

$7 + 7 =$

$9 + 3 =$

$15 + 5 =$

$13 + 7 =$

$11 + 3 =$

$17 + 9 =$

$15 + 9 =$

$13 + 15 =$

What do you notice about each answer? _____

Add the odd numbers to the even numbers.

$3 + 8 =$

$9 + 12 =$

$5 + 18 =$

$7 + 14 =$

$11 + 4 =$

$13 + 10 =$

$15 + 6 =$

$21 + 4 =$

$7 + 20 =$

$13 + 30 =$

$11 + 12 =$

$17 + 6 =$

What do you notice about each answer? _____

Add the even numbers to the odd numbers.

$6 + 7 =$

$8 + 5 =$

$10 + 9 =$

$2 + 17 =$

$10 + 29 =$

$14 + 3 =$

$8 + 13 =$

$12 + 5 =$

$14 + 7 =$

$8 + 51 =$

$16 + 9 =$

$30 + 17 =$

What do you notice about each answer? _____



Odd and even

Numbers ending in 0 2 4 6 8 are called even numbers.

Numbers ending in 1 3 5 7 9 are called odd numbers.

Circle the numbers that are even.

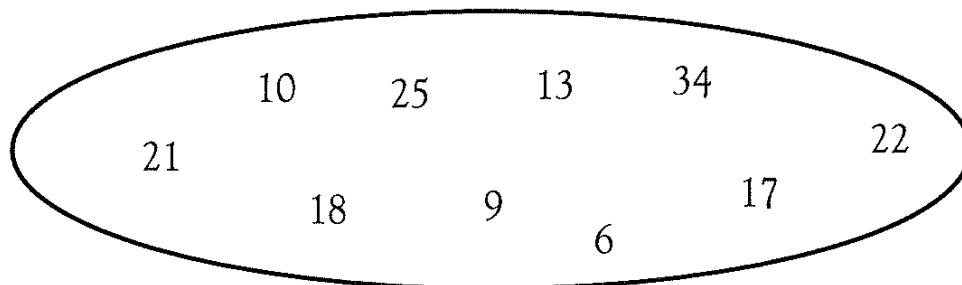

Circle the numbers that are odd.

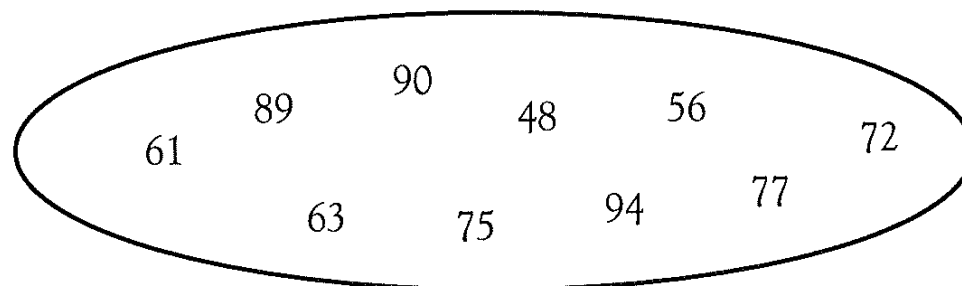

Write the odd numbers between 30 and 50.

.....

Write the even numbers between 71 and 91.

.....



Counting by 1s, 10s, and 100s

Finish each row.

Count by 1s. 24 25 26 27 28 29

Count by 10s. 31 41 51 61 71 81

Count by 100s. 134 234 334 434 534 634

Finish each row. Count by 1s.

17	18	19					
36	37	38					
69	70	71					
45	46	47					
85	86					91	

Finish each row. Count by 10s.

34	44	54					
47	57	67					
78	88	98					
9	19	29					
167	177		197				
305			335				

Finish each row. Count by 100s.

146	246	346					
312	412	512					
508	608	708					
757	857	957					
274	374						974



Missing addends

Write the missing addend.

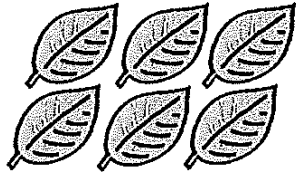

$6 + \boxed{7} = 13$

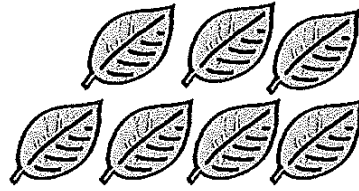

Write the missing addend.



$3 + \boxed{6} = 9$

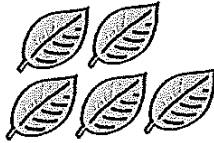
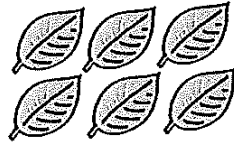

$5 + \boxed{7} = 12$

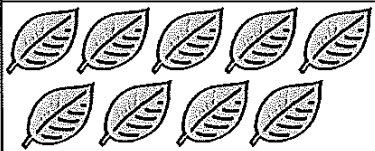
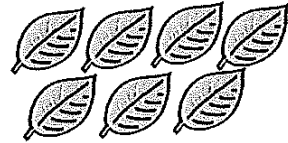

$9 + \boxed{2} = 11$

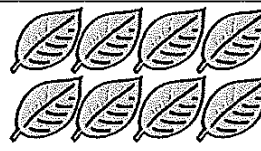

$8 + \boxed{8} = 16$

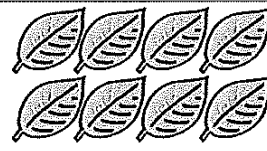

Write the missing addend.

$3 + \boxed{} = 7$

$5 + \boxed{} = 14$

$9 + \boxed{} = 12$

$8 + \boxed{} = 10$

$7 + \boxed{} = 12$

$7 + \boxed{} = 15$

$7 + \boxed{} = 12$

$9 + \boxed{} = 17$

$7 + \boxed{} = 13$

$8 + \boxed{} = 14$

$10 + \boxed{} = 13$

$4 + \boxed{} = 13$

$4 + \boxed{} = 7$

$3 + \boxed{} = 9$

$2 + \boxed{} = 11$

$8 + \boxed{} = 13$

$6 + \boxed{} = 8$

$5 + \boxed{} = 9$

$7 + \boxed{} = 8$

$8 + \boxed{} = 12$

$8 + \boxed{} = 9$

$6 + \boxed{} = 13$

$8 + \boxed{} = 16$

$5 + \boxed{} = 11$

$4 + \boxed{} = 11$

$10 + \boxed{} = 15$

$8 + \boxed{} = 11$

$4 + \boxed{} = 10$

$7 + \boxed{} = 14$

$8 + \boxed{} = 15$

$9 + \boxed{} = 14$

$6 + \boxed{} = 15$

$9 + \boxed{} = 16$

$9 + \boxed{} = 18$

$3 + \boxed{} = 10$

$5 + \boxed{} = 9$



Crossing out

Cross out one type of shape in each box.

12 - 7 = 5
(subtract)

15 - =

23 - =

16 - =

21 - =

- =

- =

Fact families



Use the 3 numbers to write 4 different facts.

$6 + 7 = 13$

$7 + 6 = 13$

$13 - 7 = 6$

$13 - 6 = 7$

$16 + 4 = 20$

$+ =$

$- =$

$- =$

$6 + 5 = 11$

$7 + 8 = 15$

$8 + 12 = 20$

$10 + 8 = 18$

$8 + 9 = 17$

$9 + 7 = 16$

$14 + 6 = 20$

$11 + 8 = 19$



Addition fact families

Circle the number sentence that is in the same fact family.

$$\begin{array}{l} 12 - 5 = 7 \\ 5 + 7 = 12 \end{array}$$

$$12 - 4 = 8$$

$$7 + 5 = 12$$

$$12 + 12 = 24$$

$$\begin{array}{l} 10 - 8 = 2 \\ 8 + 2 = 10 \end{array}$$

$$8 - 6 = 2$$

$$2 + 8 = 10$$

$$8 - 2 = 6$$

Circle the number sentence that is in the same fact family.

$$\begin{array}{l} 7 + 8 = 15 \\ 8 + 7 = 15 \end{array}$$

$$7 + 5 = 12$$

$$15 - 8 = 7$$

$$8 - 7 = 1$$

$$\begin{array}{l} 17 - 6 = 11 \\ 11 + 6 = 17 \end{array}$$

$$17 - 11 = 6$$

$$17 + 6 = 23$$

$$5 + 6 = 11$$

$$\begin{array}{l} 14 - 5 = 9 \\ 14 - 9 = 5 \end{array}$$

$$9 - 3 = 6$$

$$14 + 9 = 23$$

$$5 + 9 = 14$$

$$\begin{array}{l} 9 + 7 = 16 \\ 7 + 9 = 16 \end{array}$$

$$16 - 9 = 7$$

$$16 + 7 = 23$$

$$9 - 7 = 2$$

$$\begin{array}{l} 19 - 9 = 10 \\ 19 - 10 = 9 \end{array}$$

$$9 + 3 = 12$$

$$9 + 10 = 19$$

$$18 - 8 = 10$$

$$\begin{array}{l} 4 + 7 = 11 \\ 11 - 4 = 7 \end{array}$$

$$11 + 4 = 15$$

$$7 + 4 = 11$$

$$7 + 7 = 14$$

Write the fact family for each group of numbers.

5, 6, 11

6, 10, 4

5, 13, 8

Subtraction



Say and count as you write.

10 altogether. How many in the tent?

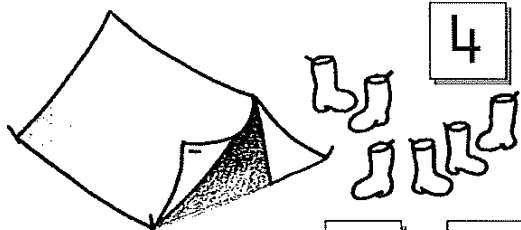

4

$$10 - 6 = 4$$

18 altogether. How many in the tent?

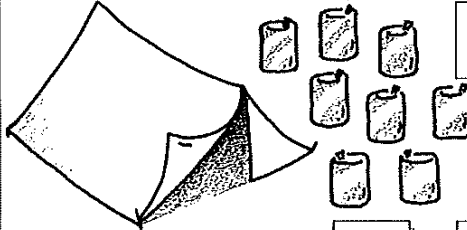

10

$$18 - 8 = 10$$

19 altogether. How many in the tent?

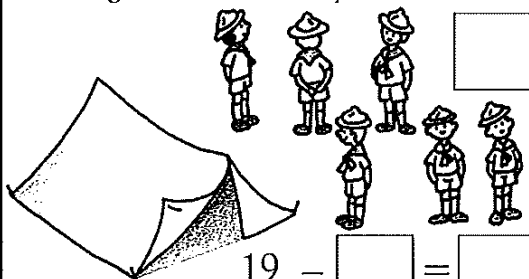

$$19 - \square = \square$$

21 altogether. How many in the tent?

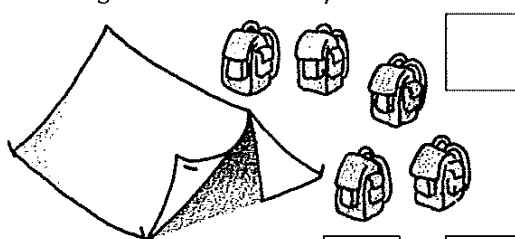

$$21 - \square = \square$$

Say as you write.

$$16 - 4 = 12$$

$$18 - \square = 7$$

$$12 - \square = 2$$

$$20 - \square = 14$$

$$19 - \square = 5$$

$$15 - \square = 9$$

$$25 - \square = 4$$

$$27 - \square = 11$$

$$30 - \square = 10$$

Say as you write.

$$15 - 5 = 10$$

$$30 - \square = 0$$

$$16 - 0 = \square$$

$$23 - 10 = \square$$

$$40 - \square = 0$$

$$28 - 8 = \square$$

Counting by 2s



Count by 2s. 12 14 16 18 20 22

Count by 2s. 31 33 35 37 39 41

Finish each row. Count by 2s.

17	19	21					
36	38	40					
72	74	76					
43	45	47					
14	16					26	
39		43					53

Finish each row. Count by 2s.

20							34
75							89
44							58
69							83
31							45
88							102

Finish each row. Count by 2s.

				28			34
			53			59	
					87		91
	48		52				
					97	99	
		50			56		

Name _____

Date _____

Count the objects, and fill in the number bond or place value chart. Complete the sentences to add the tens and ones.

1.

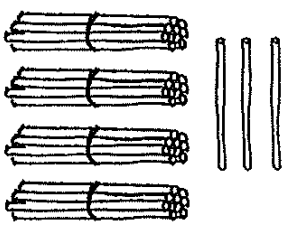
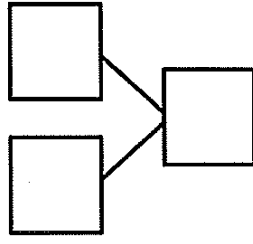
40 and 3 make ____.

$40 + 3 = \underline{\quad}$

2.

40 and 6 make ____.

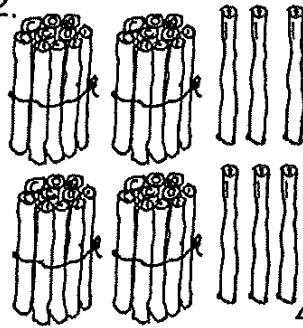
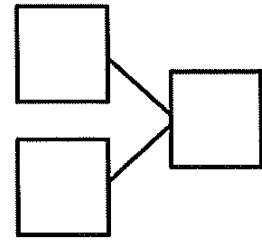
$40 + 6 = \underline{\quad}$

3.

$57 = \underline{\quad} + \underline{\quad}$

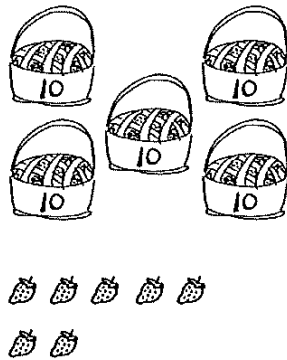
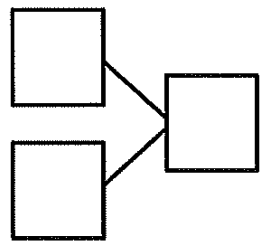
7 more than 50 is ____.

4.

$75 = \underline{\quad} + \underline{\quad}$

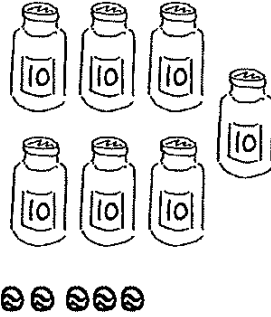
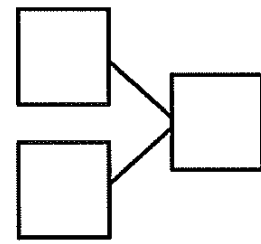
5 more than 70 is ____.

5.

$\underline{\quad} + \underline{\quad} = \underline{\quad}$

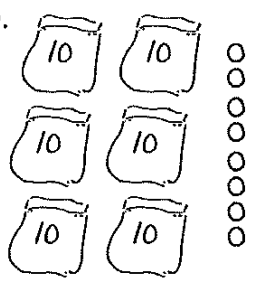
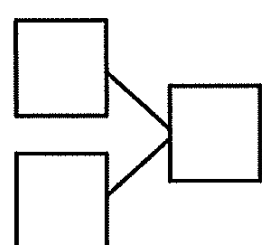
$\underline{\quad}$ tens + $\underline{\quad}$ ones = ____

6.

$\underline{\quad} + \underline{\quad} = \underline{\quad}$

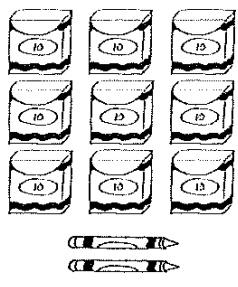
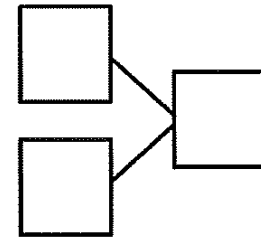
$\underline{\quad}$ tens + $\underline{\quad}$ ones = ____

7.



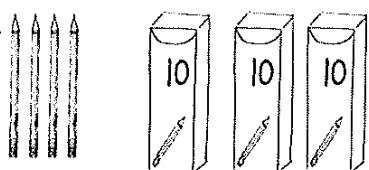
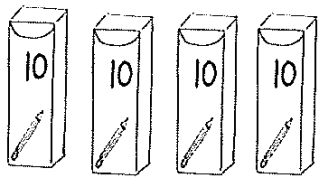

tens	ones

_____ + _____ = _____

_____ tens + _____ ones = _____

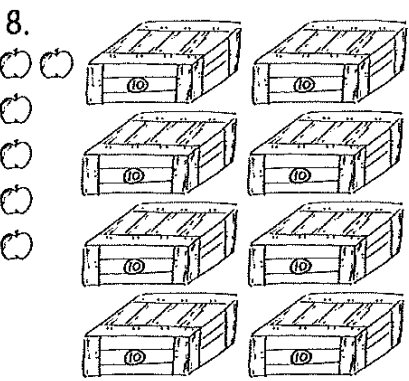
8.



tens	ones

_____ + _____ = _____

_____ tens + _____ ones = _____

9.

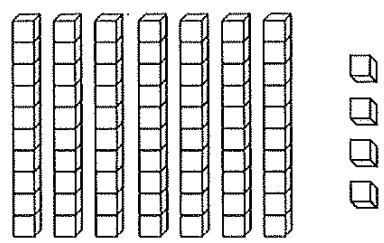

tens	ones

_____ + _____ = _____

_____ tens + _____ ones = _____

10.

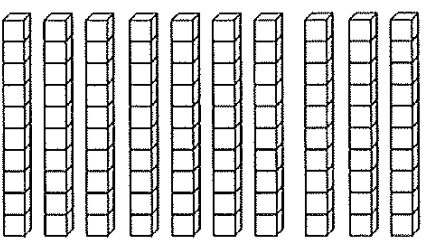

tens	ones
	0

_____ + _____ = _____

_____ tens + _____ ones = _____

11. Complete the sentences to add the tens and ones.

a. $50 + 6 = \underline{\quad}$

b. $\underline{\quad} + 9 = 89$

c. $5 \text{ tens} + \underline{\quad} \text{ ones} = 56$

d. $9 \text{ ones} + 8 \text{ tens} = \underline{\quad}$

Name _____

Date _____

Read the word problem.

Draw a tape diagram or double tape diagram and label.

Write a number sentence and a statement that matches the story.

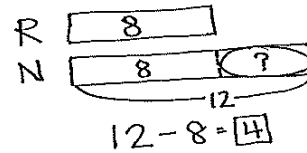

1. Peter has 3 goats living on his farm. Julio has 9 goats living on his farm.
How many more goats does Julio have than Peter?

-
2. Willie picked 16 apples in the orchard. Emi picked 10 apples in the orchard.
How many more apples did Willie pick than Emi?

3. Lee collected 13 eggs from the hens in the barn. Ben collected 18 eggs from the hens in the barn. How many fewer eggs did Lee collect than Ben?

4. Shanika did 14 cartwheels during recess. Kim did 20 cartwheels. How many more cartwheels did Kim do than Shanika?